

NOVA - NHS HYDRAULIC LEVELER

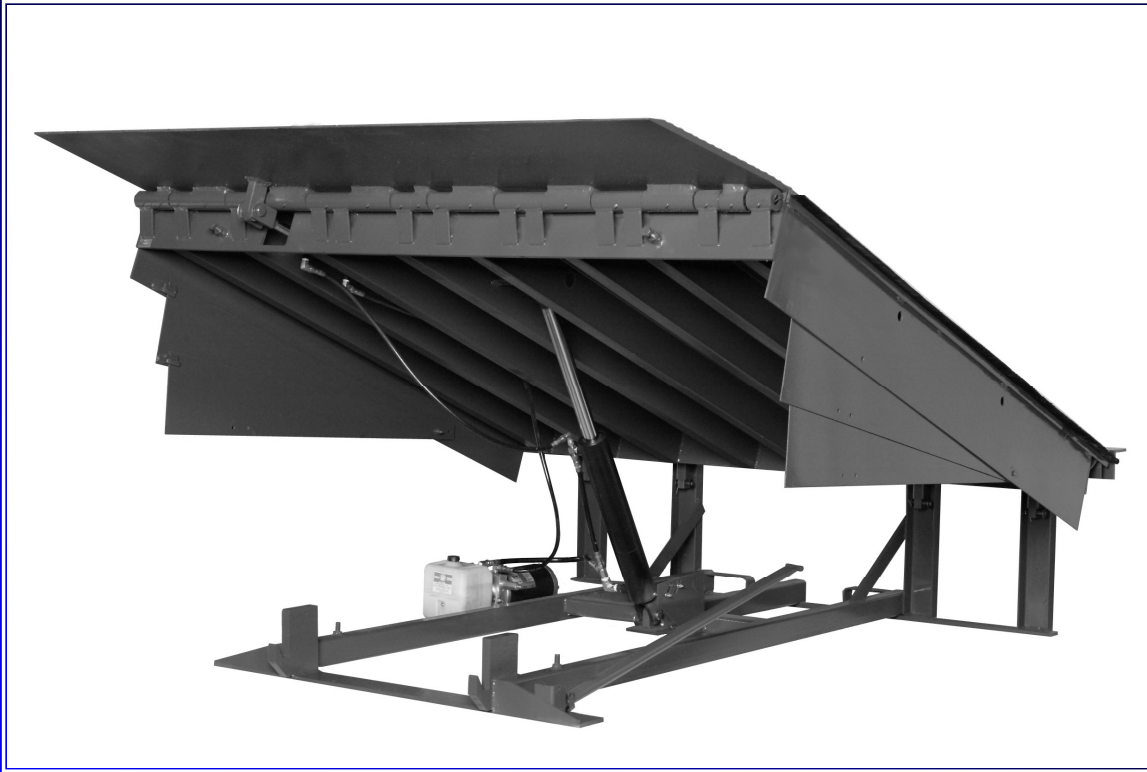

Product Features:

- Regenerative Hydraulic System
- 5 Year Warranty
- “Easy Clean” Frame Design
- “Velocity Fuse” Limits Drop 1” to 3”
- Integral Maintenance Strut
- Barrier Lip Option Available

NOVA’s Premium Hydraulic Dock leveler is designed to provide excellent reliability and structural durability at an affordable price. Easy push button operation with a reliable Regenerative Hydraulic system makes this full featured leveler a “True Value”.



NOVA TECHNOLOGY

800-236-7325 • www.novalocks.com

NOVA - NHS HYDRAULIC LEVELER

ARCHITECTURAL SPECIFICATIONS

DESCRIPTION :

Dock leveler size (nominal):

width ____ x length ____

Capacity: _____ MH-14.1/ANSI 1987

Lip size: __16" __18" __20"
__ Reduced crown __ Extended chamfer

Bumpers:
__ 4"-1014 __6"-1014 __4"-2011
__ _____

Weather seals: __ Rubber __ Brush

Options:
__ 2" Foam Insulated Deck
__ 3-Wheel Fork Truck Support
__ 24" Pit Kit
__ Full Depth Pit Conversion
__ Steel Pan
__ Barrier Lip

OPERATION :

Push button is depressed and held activating the hydraulic system that lifts the deck from a stored position. When the deck reaches the fully elevated position, the lip cylinder is activated extending the lip assembly. Attendant releases the push button when the lip is fully extended and the deck descends to the trailer bed. The lip will rest on the trailer bed and the deck will float with the trailer (12" above/below dock operating range). If a trailer departs prior to storing the leveler the velocity fuse will limit the movement of the deck within 1" to 3". The proper sequence, after loading/unloading is complete, is for the attendant to depress the push button lifting the leveler from the trailer bed. The push button is held until the lip falls pendant and then released allowing the leveler to rest in the lip keepers.

STRUCTURAL :

The leveler is a welded box style construction with piano style lip hinge. The deck and lip are 50-55,000 PSI yield safety tread plate. The deck is supported by formed steel channel with structural steel headers and toe guards. Lip hinge spools alternately welded to the front header and lip are connected by a solid hinge pin. Continuous 1" rear hinge pin mounted in compression on a structural steel angle supported by (4) structural steel channel uprights.

WARRANTY :

1 Year Parts and Labor Warranty with Additional
4 Year Structural Components Warranty
(Lifetime Rear Hinge Warranty May Be Available Based on Usage)

SAFETY FEATURES :

Heavy-duty regenerative hydraulic system powered by a 1 HP motor with a NEMA 4X control box.

Equipped with velocity fuse stopping deck travel within 1" to 3". Lip is yieldable to accidental impact. Also included is an integral maintenance strut, night locks, and safety marked full range toe guards.

* Available with a Barrier Lip

Recommended Equipment:

Nova Truck Lock System

to restrain trucks / trailers during the loading/unloading process.



NOVA TECHNOLOGY

N90 W14507 Commerce Drive ▪ Menomonee Falls, WI 53051

800-236-7325 ▪ www.novalocks.com